

## Figure A6-1 Theoretical wiring diagram

Applicable to cars produced prior to 1992 model year

For details applicable to 1992 model year cars, refer to TSD 5136

see Fig. A6-1

### A6-1 Theoretical wiring diagram

1	Starter relay
2	Engine coolant temperature switch
3	Secondary air pump clutch
4	Secondary air injection system control module (PCMA)
5	Speed control system
6	Stop lamps
7	Starter relay
8	Engine run sensor (ERS)
9	ACU control relay
10	Fuel pump relay (FPR)
11	Fuel pump(s)
12	Inertia fuel shutoff switch (IFSS)
13	5-way plug and socket
14	K-Motronic control module (PCME)
15	ACU compressor
16	Drive signal
17	Fuseboard F1, fuse B9, 25amp
18	Electro-hydraulic actuator (EHA)
19	Idle air control valve (IACV)
20	Purge control valve
21	Cold start injector
22	Fuseboard F1, fuse B4, 20amp
23	Splice 10
24	Variable ride control module
25	Warning panel-CHECK ENGINE
26	Over-voltage relay
27	Kick-down relay
28	Purge cut-off solenoid
29	Engine coolant temperature switch
30	Throttle position sensor (TPS)
31	Crankshaft position sensor (CPS)
32	Engine speed sensor
33	Manifold absolute pressure sensor (MAP)-ignition
34	On-board diagnostic button
35	Heated oxygen sensor (HO2S)
36	Air flow sensor (AFS)
37	Engine coolant temperature sensor (ECTS)
38	Parameter code socket (K-Motronic)
39	Group 2 ignition distributor
40	Group 2 ignition coil
41	Group 2 ignition amplifier module
42	Group 1 ignition amplifier module
43	Group 1 ignition coil
44	Group 1 ignition distributor
45	Boost control solenoid valve
46	Manifold absolute pressure sensor (MAP)-Boost
47	Parameter code socket (Boost)
48	Boost control module (PCMB)

49	'B' bank knock sensor (KS)
50	'A' bank knock sensor (KS)

**Note:**  
The diagram shows a turbocharged car fitted with emission control systems.

**Warning:**  
Dependent upon the specification of a car some of the components shown may not be fitted.

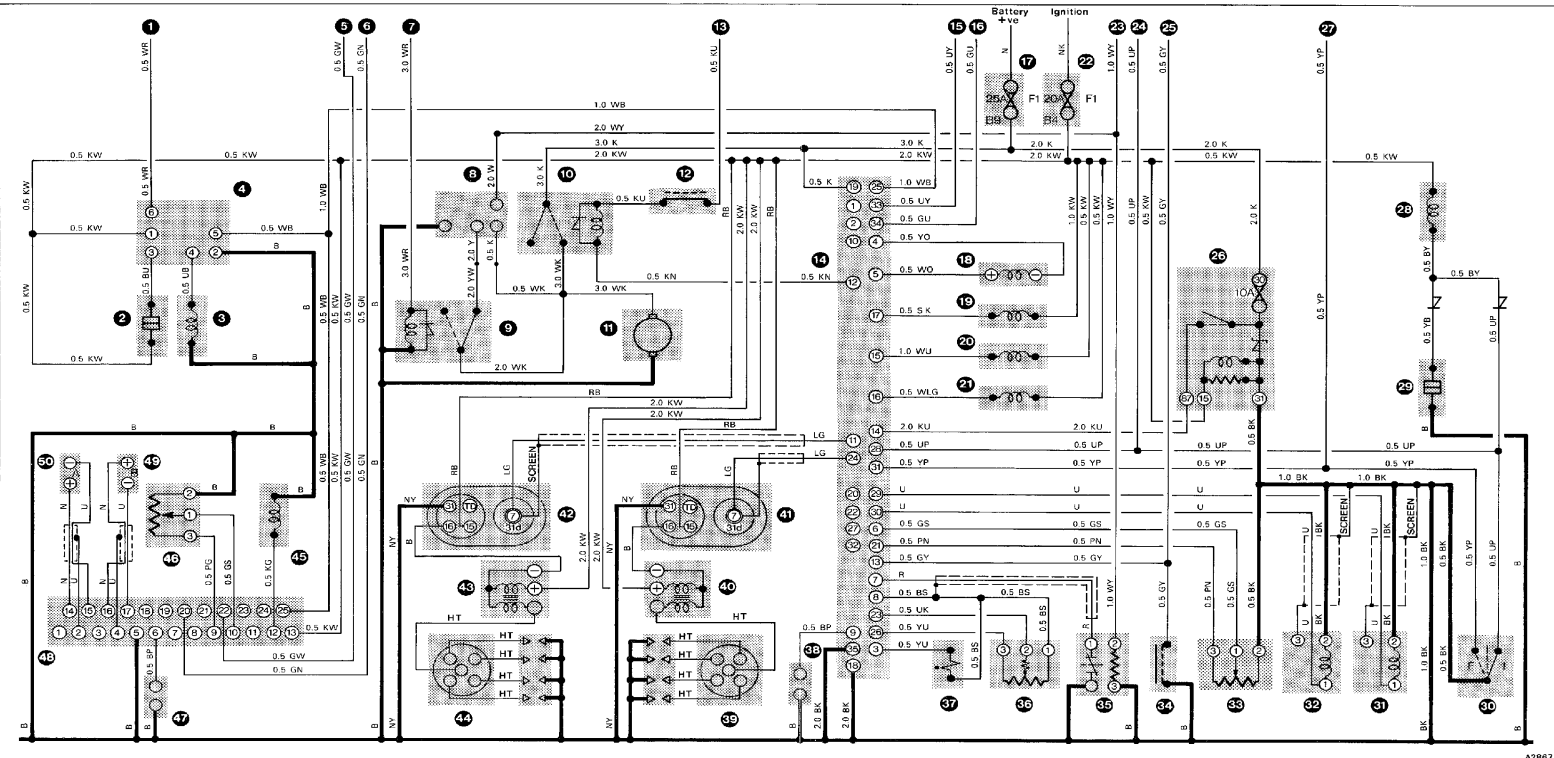

A2867