

ROLLS-ROYCE

BENTLEY



**CARBURETTOR and FUEL SYSTEM
FUEL TANK**

B6/2
Amendment 5

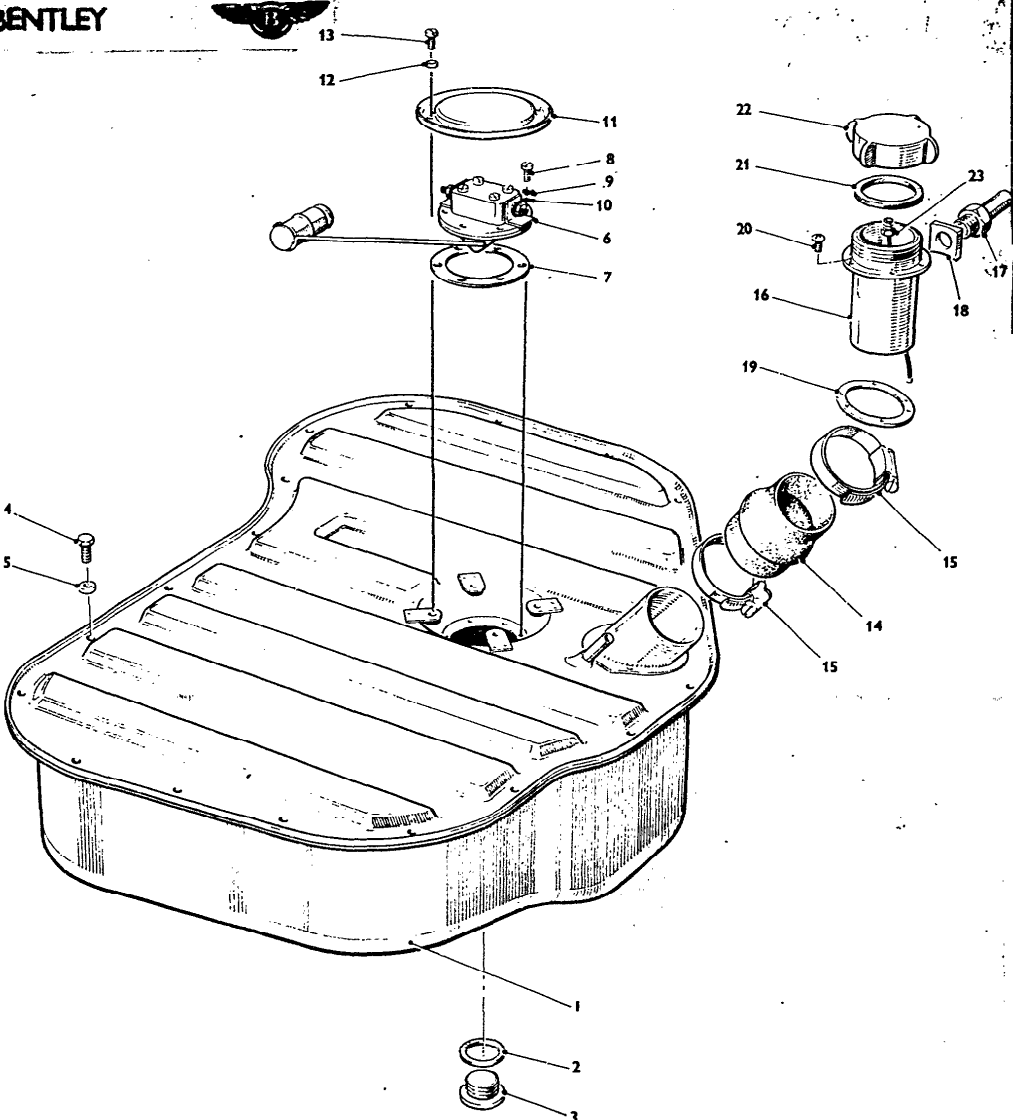

Ref.	Part No.	Description	No. off	Remarks
1	UR 19265	FUEL TANK-Assembly	1	
2	UR 16450	WASHER-Joint-Drain Plug	1	
3	UG 526	PLUG-Drain	1	
4	UA 102	SETScrew-Fuel Tank to Boot Floor	19	
5	UA6102/Z	WASHER-Heavy-Setscrew	19	
6	UR 13591	FUEL GAUGE UNIT-Electric	1	
7	UR 17396	GASKET-Fuel Gauge Unit	1	
8	X 1804/Z	SCREW-Fuel Gauge Unit	6	
9	X 9005/Z	WASHER-Fuel Gauge Unit	6	
10	RE 3658	WASHER-Fuel Gauge Unit	6	
11	UR 13588	COVER-Fuel Gauge Unit	1	
12	X 4404/Z	WASHER-Fuel Gauge Cover	4	
13	X 1907/Z	SCREW-Fuel Gauge Cover	4	
14	UR 13769	SLEEVE-Filler Head to Petrol Tank	1	
15	RE 6739	CLIP-Sleeve to Tank	2	
16	UR 17090	FILLER HEAD-Petrol Tank Assembly	1	
17	UR 16344	UNION and TUBE-Filler Head	1	
18	UR 16343	WASHER	1	
19	UR 13770	JOINT-Filler Head-Petrol Tank	1	
20	UA 6804/Z	SCREW-Filler Head	6	
21	UB 432	WASHER-Sealing Filler Cap	1	
22	UR 13587	CAP-Petrol Filler	1	
23	UR 13592	PLUG-Petrol Filler Cap	1	
UR 19238		AS ABOVE EXCEPT: FILLER HEAD-Assembly-Petrol Tank	1	North American cars only
		<u>CAR SERIAL NOS</u>		
		STANDARD CARS: 19427, 20378 to 23148 except 23133, 23141		
		COACHBUILT CARS: 20171 to 21728		
		LWB CARS: 20426 to 23171		

CARBURETTOR and FUEL SYSTEM
FUEL TANK

B 6/2
Amendment 4

CAR SERIAL NOS
STANDARD CARS:- 9001 onwards.
COACHBUILT CARS:- 9040 to 9769 incl
9770 Onwards.
L. W. B. CARS:- 9067 onwards.